

Design

The Hallite 15 rod seal has been well proven in many applications requiring a compact, low friction seal to work efficiently both at low and high pressures.

The seal comprises a rubberised fabric U ring to give strength and durability, to which is moulded a rubber header. It is designed to have a controlled pre-load across the angled rubber lips which are accurately machine trimmed, to ensure a good seal at low pressure.

The seal becomes more effective as the pressure increases and the rubberised fabric deforms to the housing increasing the seal contact area. The surface of the fabric has pockets which retain lubrication to reduce friction and wear.

The proportions of the range have been determined to give a satisfactory performance when used with the recommended operating conditions. Many other sizes are available outside this range.

The range should be fitted to split housings as shown, but sizes marked* can be fitted to a grooved gland housing, if assembled with care.

NB: Size lists give "on line" tolerances for rod applications.

Features

- Well proven seal
- Contamination resistance
- Good wear resistance

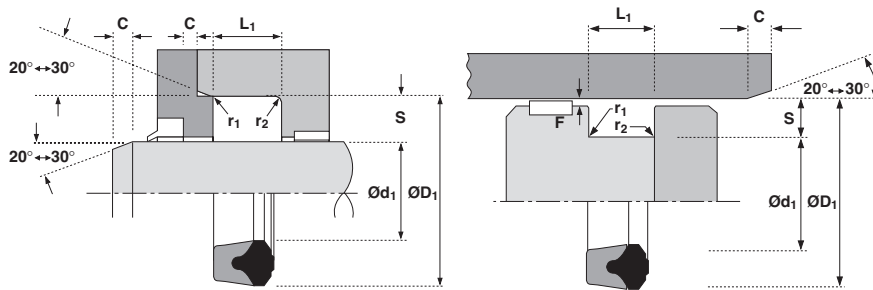

Technical details

Operating conditions

Maximum Speed	0.5 m/sec
Temperature Range	-30°C + 100°C
Maximum Pressure	300 bar

Inch

Maximum Speed	1.5 ft/sec
Temperature Range	-22°F + 212°F
Maximum Pressure	4500 p.s.i.

Maximum extrusion gap

Pressure bar	100	160	250	300
Maximum Gap mm	0.45	0.4	0.3	0.25
Pressure p.s.i.	1500	2400	3750	4500

Figures show the maximum permissible gap all on one side using minimum rod \varnothing and maximum clearance \varnothing . Refer to Housing Design section.

Surface roughness

	μmRa	μmRt	μinCLA	μinRMS
Dynamic Sealing Face – Rod $\varnothing d_1$	0.1 < > 0.4	4 max	4 < > 16	5 < > 18
Static Sealing Face – Rod $\varnothing D_1$	1.6 max	10 max	63 max	70 max
Dynamic Sealing Face – Piston $\varnothing D_1$	0.1 < > 0.4	4 max	4 < > 16	5 < > 18
Static Sealing Face – Piston $\varnothing d_1$	1.6 max	10 max	63 max	70 max
Static Housing Faces L_1	3.2 max	16 max	125 max	140 max

Chamfers & Radii

Groove Section $\leq S$ mm	4.0	5.0	6.0	7.5	10.0
Min Chamfer C mm	2.0	2.5	3.0	4.0	5.0
Max Fillet Rad r_1 mm	0.2	0.4	0.8	0.8	0.8
Max Fillet Rad r_1 mm	0.4	0.8	1.2	1.2	1.2

Tolerances

$\varnothing d_1$	$\varnothing D_1$	L_1 mm
f9	Js11	+0.25 -0
js11	H9	+0.25 -0



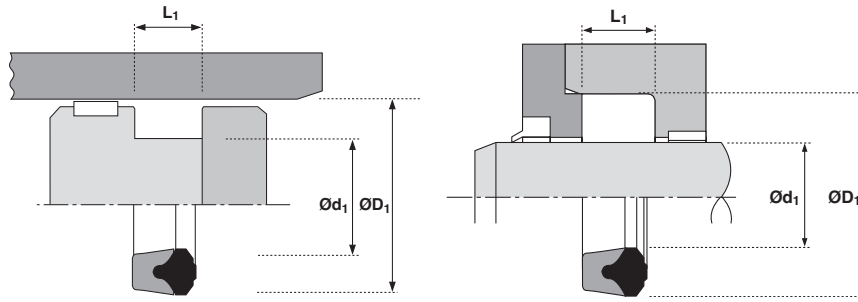

Ød1	TOL f9	ØD1	TOL Js11	L1 +0.25-0	PART No.
16	-0.016 -0.059	26	+0.07 -0.07	8.0	0754300
20	-0.020 -0.072	28	+0.07 -0.07	6.4	2137000*
22	-0.020 -0.072	30	+0.07 -0.07	6.4	2137100*
22	-0.020 -0.072	32	+0.08 -0.08	9.0	0377300
25	-0.020 -0.072	33	+0.08 -0.08	6.4	2137200*
28	-0.020 -0.072	36	+0.08 -0.08	6.4	2137300*
28	-0.020 -0.072	40	+0.08 -0.08	9.0	0690700
30	-0.020 -0.072	38	+0.08 -0.08	6.4	2137400*
30	-0.020 -0.072	40	+0.08 -0.08	7.5	0032400*
32	-0.025 -0.087	40	+0.08 -0.08	6.4	2137500*
35	-0.025 -0.087	43	+0.08 -0.08	6.4	2137600*
35	-0.025 -0.087	50	+0.08 -0.08	11.0	0874400
36	-0.025 -0.087	44	+0.08 -0.08	6.4	2137700*
36	-0.025 -0.087	48	+0.08 -0.08	9.0	0690600*
40	-0.025 -0.087	48	+0.08 -0.08	6.4	2137800*
40	-0.025 -0.087	50	+0.08 -0.08	7.5	0188600*
40	-0.025 -0.087	50	+0.08 -0.08	10.5	1252100*
45	-0.025 -0.087	55	+0.10 -0.10	8.0	2137900*
45	-0.025 -0.087	60	+0.10 -0.10	10.0	1022800*

Ød1	TOL f9	ØD1	TOL Js11	L1 +0.25-0	PART No.
50	-0.025 -0.087	60	+0.10 -0.10	8.0	1204400*
55	-0.030 -0.104	65	+0.10 -0.10	8.0	0208700*
56	-0.030 -0.104	66	+0.10 -0.10	8.0	2138000*
56	-0.030 -0.104	71	+0.10 -0.10	12.0	0332600*
60	-0.030 -0.104	70	+0.10 -0.10	8.0	0208500*
60	-0.030 -0.104	80	+0.10 -0.10	14.0	0391400*
63	-0.030 -0.104	75	+0.10 -0.10	9.6	2138100*
65	-0.030 -0.104	77	+0.10 -0.10	9.6	2138200*
70	-0.030 -0.104	80	+0.10 -0.10	7.5	0057700*
70	-0.030 -0.104	82	+0.11 -0.11	9.6	2146800*
70	-0.030 -0.104	85	+0.11 -0.11	12.0	0384500
80	-0.030 -0.104	92	+0.11 -0.11	9.6	2138300*
90	-0.036 -0.123	102	+0.11 -0.11	9.6	2138400*
90	-0.036 -0.123	105	+0.11 -0.11	9.5	2174600*
100	-0.036 -0.123	115	+0.11 -0.11	12.0	2138500*
100	-0.036 -0.123	120	+0.11 -0.11	15.0	0466100*
110	-0.036 -0.123	125	+0.13 -0.13	12.0	0749300*
115	-0.036 -0.123	130	+0.13 -0.13	12.0	2136900*

For piston sealing tolerances refer to technical details